



***Society of Cable  
Telecommunications  
Engineers***

---

**ENGINEERING COMMITTEE  
Interface Practices Subcommittee**

---

**AMERICAN NATIONAL STANDARD**

**ANSI/SCTE 46 2007**

**Test Method for AC to DC Power Supplies**

## **NOTICE**

The Society of Cable Telecommunications Engineers (SCTE) Standards are intended to serve the public interest by providing specifications, test methods and procedures that promote uniformity of product, interchangeability and ultimately the long term reliability of broadband communications facilities. These documents shall not in any way preclude any member or nonmember of SCTE from manufacturing or selling products not conforming to such documents, nor shall the existence of such standards preclude their voluntary use by those other than SCTE members, whether used domestically or internationally.

SCTE assumes no obligations or liability whatsoever to any party who may adopt the Standards. Such adopting party assumes all risks associated with adoption of these Standards or Recommended Practices, and accepts full responsibility for any damage and/or claims arising from the adoption of such Standards or Recommended Practices.

Attention is called to the possibility that implementation of this standard may require use of subject matter covered by patent rights. By publication of this standard, no position is taken with respect to the existence or validity of any patent rights in connection therewith. SCTE shall not be responsible for identifying patents for which a license may be required or for conducting inquiries into the legal validity or scope of those patents that are brought to its attention.

Patent holders who believe that they hold patents which are essential to the implementation of this standard have been requested to provide information about those patents and any related licensing terms and conditions. Any such declarations made before or after publication of this document are available on the SCTE web site at <http://www.scte.org>.

All Rights Reserved

© Society of Cable Telecommunications Engineers, Inc. 2007  
140 Philips Road  
Exton, PA 19341

## **TABLE OF CONTENTS**

<b>1.0</b>	<b>SCOPE AND DEFINITIONS.....</b>	<b>1</b>
<b>2.0</b>	<b>EQUIPMENT.....</b>	<b>4</b>
<b>3.0</b>	<b>SET-UP DIAGRAM.....</b>	<b>4</b>
<b>4.0</b>	<b>TEST PROCEDURES.....</b>	<b>6</b>
<b>5.0</b>	<b>NORMATIVE REFERENCES.....</b>	<b>16</b>

## SCOPE AND DEFINITIONS

### 1. SCOPE

To characterize, document and define test methods for AC to DC power supplies. These tests involve the measurement of AC input parameters and DC output parameters. The application of uniform test methods for power supplies will allow fair performance comparisons to be made between different power supplies.

There are repetitive tests throughout this test document, in which many of the tests can be combined and performed at the same time.

#### 1.1. Definitions

##### 1.1.1. Power Consumption

- 1.1.1.1. Apparent AC Power: the scalar product of the RMS input voltage and RMS input current (Eq. 1).

$$P_{IN}(\text{app}) = V_{IN} \times I_{IN} \quad (\text{VA}) \quad (1)$$

The apparent power unit is volt-ampere (VA) and is the vector sum of the real and reactive power vectors in the power triangle (Figure 1).

- 1.1.1.2. Real AC Power: the instantaneous product of the time varying voltage and time varying current (Eq. 2).

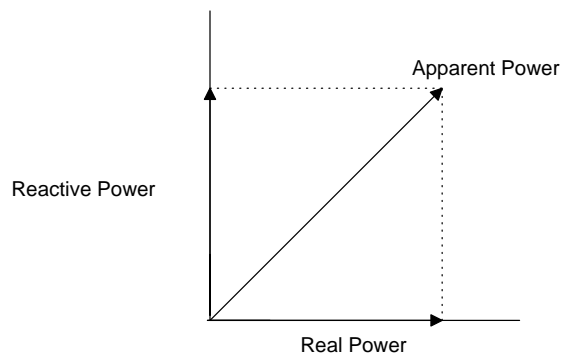

Figure 1: Power Triangle

$$P_{IN}(\text{real}) = \frac{1}{T} \int_0^T v_{IN}(t) \cdot i_{IN}(t) dt \quad (\text{watts}) \quad (2)$$

where T is the period of the waveform

- 1.1.2. Efficiency: the ratio of output power to input power. This unit-less parameter will be expressed in percentage form. Efficiency is calculated using Equation 3:

$$\% \text{Eff} = 100 \times \left[ \frac{\sum_{m=1}^n P_{OUT\ m}}{P_{IN}(\text{real})} \right] \quad (3)$$

where  $P_{OUT} = V_{OUT} \times I_{OUT}$  and 'n' represents the number of outputs

- 1.2.3 AC Input Loading: the relationship of a change in the input current usage versus a change in the input voltage for a constant load on the output. This is a directly measured set of data.
- 1.2.4 Line Regulation: the relationship of a change in the output DC voltage versus a change in the AC input voltage while holding the load current constant. May be expressed as a difference between two input conditions.

$$\text{Line regulation (mV)} = |(V_{OUT})_{INPUTSTATE\ 1} - (V_{OUT})_{INPUTSTATE\ 2}| \quad (4)$$

- 1.2.5 Load Regulation: the relationship of a change in the output DC voltage versus a change in the DC output load current while holding the input voltage constant. May be expressed as a difference between the rated load state and the specified minimum load state.

$$\text{Load regulation (mV)} = |(V_{OUT})_{LOADSTATE\ 1} - (V_{OUT})_{LOADSTATE\ 2}| \quad (5)$$

- 1.2.6 Power Factor: the ratio of the real power to the apparent power required to operate a device (refer to Figure 1). Power Factor may be measured directly (from a power analyzer) or it may be calculated using the following relationship (refer to Equations 1 and 2):

$$PF = \frac{P_{IN}(\text{real})}{P_{IN}(\text{app})} \quad (6)$$

- 1.2.7 Voltage Ripple: the amplitude of any residual AC voltage which is present on the DC output of the DUT. The "voltage ripple" is a directly measured quantity.

- 1.2.8 DUT: the “device under test” for this test procedure refers to the DC power supply assembly only. It may be tested within the confines of the "intended device" (for heat distribution and filtering purposes), but the input and output connections must be separated from the “intended device” to allow greater control of test conditions. Final performance within the “intended device” should reflect equivalent performance.
- 1.2.9 Hold-up Time: the time duration from when the AC input voltage is removed from the power supply input until the output voltage falls below the minimum specification. The AC input voltage shall be removed at the zero crossing (within  $\pm 1$  msec of the zero crossing) of the input waveform.
- 1.2.10 In-rush Current: the instantaneous peak input current that is measured during the initial powering sequence. It shall be performed with the AC input voltage at or near the zero crossing (within  $\pm 1$  msec of the zero crossing). It is to be performed with the power supply capacitors completely discharged (>99% discharged).
- 1.2.11. Start-up Time: the time duration from the first in-rush current pulse to the time when all DC output voltages reach their minimum specified operating points. Note that the in-rush current timing reference is the same as in 1.2.10 (above).

## 2.0 EQUIPMENT

2.1 The Test Procedure Introduction document, ANSI/SCTE 96 2003, describes and specifies some of the basic test equipment which may be required. Much of the equipment required for these procedures is more specialized in nature. Details as to specific requirements will be called out within the individual test procedures, as needed.

2.2 Test Equipment: the following table is a list of suitable test equipment. Functionally equivalent units may be substituted as desired.

Table 1.

Item #	Manufacturer	Model	Description
1	Alpha Technologies	XM2-915	15 AMP Ferro-resonant Power Supply
2	Staco	3PN2210B	Adjustable Transformer (10A)
3	Voltech	PM100	Single Phase Power Analyzer
4	Transistor Devices	DLM50-20-100	Electronic Adjustable Load
5	Tektronix	TDS-684	Digitizing Oscilloscope
6	Generic	NA	1:1 Coaxial/Shielded probe
7	Fluke	Model 87	True RMS Digital Voltmeter
8	Xentech	EIT5874	Isolation transformer
9	Pearson	110	Wide-band Current Monitor
10	Generic	15A-125VAC	3 conductor to 2 conductor ISO plug
11	Tektronix	P6109B	10:1 Oscilloscope Probe
12	Ohmite	TC025PA1R00J	1 $\Omega$ Power Resistor 25W (Non-inductive)
13	Ohmite	TC025PA5R00J	5 $\Omega$ Power Resistor 25W (Non-inductive)

## 3.0 SET-UP

Construct the test system as shown in Figure 2. Note the use of “isolation” plugs isolates the ground return, therefore the devices should be powered from a ground fault circuit interrupting system (GFCI).

All wiring should be of a sufficient gauge to minimize voltage drops due to wire resistance. *Extreme care should be exercised whenever exposed AC wiring and hazardous voltages and high temperatures are present.*

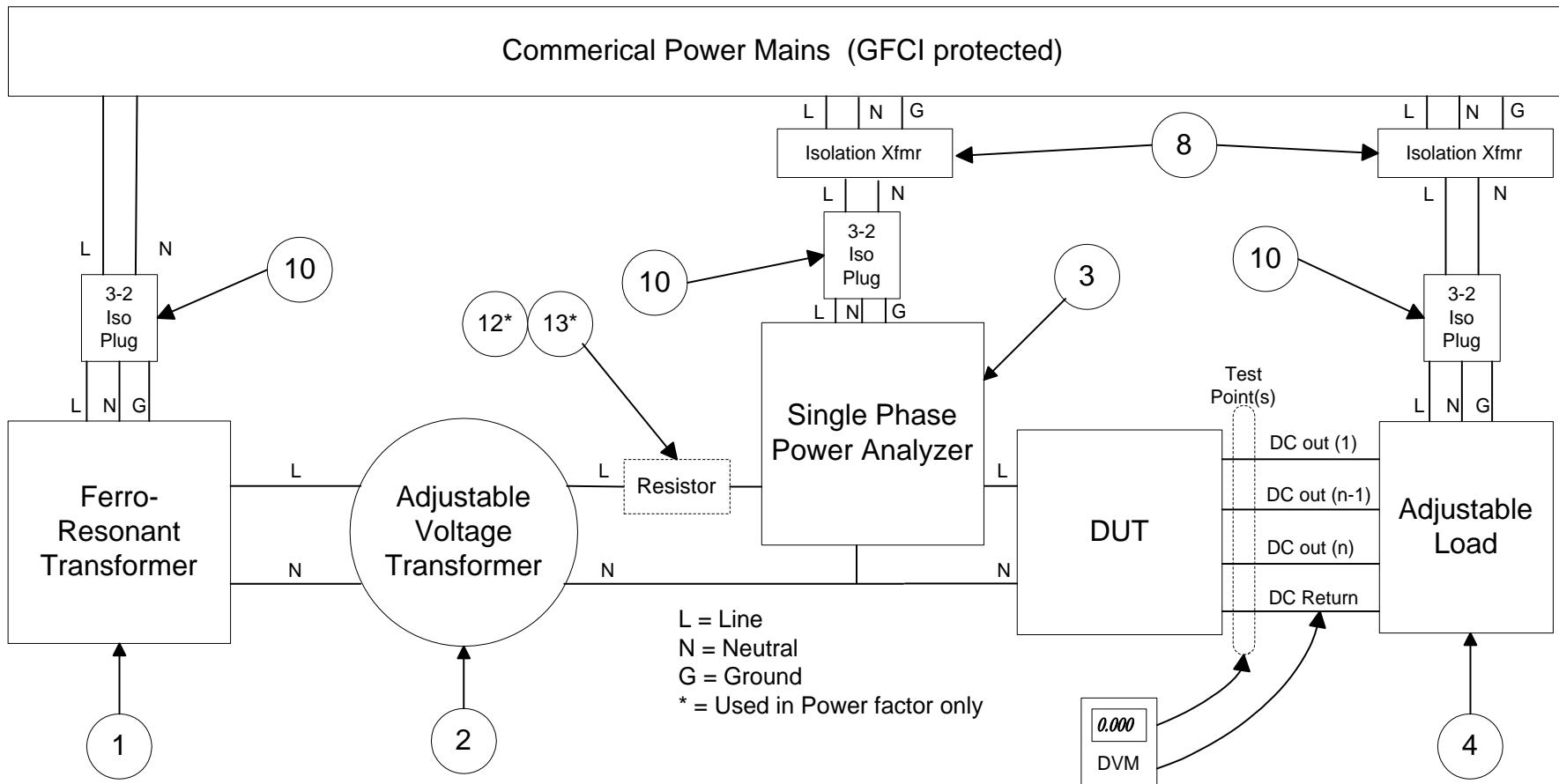

Figure 2: Connection Diagram

## 4.0 TEST PROCEDURES

The power supply unit (DUT) will be tested as a stand-alone unit electrically independent of the intended equipment. It may be tested within the confines of the "intended device" (for heat distribution and filtering purposes), but the input and output connections must be separated from the "intended device" to allow greater control of test conditions. Final performance within the "intended device" should reflect equivalent performance.

To evaluate noise and other spurious emissions, testing should be performed within the intended equipment by referring to ANSI/SCTE 82 2003.

### 4.1 POWER CONSUMPTION

4.1.1 Set the input AC voltage to the maximum specified input level using the adjustable transformer (item #2). Measure the input voltage using the power analyzer (item #3).

4.1.2 Set the electronic load (item #4) to the specified maximum output load current. Use a DVM (item #7) in series with the DC output or the electronic load ammeter (item #4) may also be used. If the power supply being tested has multiple DC voltage outputs adjust each DC output to the specified maximum output load current. Readjust the input AC voltage if it has changed.

4.1.3. Using the power analyzer, measure and record the input AC power consumption,  $P_{IN}(\text{real})$ , and the input AC voltage,  $V_{IN}$  (item #3).

4.1.4. Holding the input AC voltage constant, adjust the electronic load(s) on the DC output(s) to the next load current(s) as desired. Readjust the input AC voltage (item #2) if it has changed. Repeat the measurements of 4.1.3 for each current.

4.1.5. Repeat 4.1.2 through 4.1.4 while adjusting the input AC voltage transformer in steps, as desired, from the maximum to the minimum rated input levels for the AC voltage.

### 4.2 AC INPUT LOADING

4.2.1. Set the input AC voltage to the maximum specified input level using the adjustable transformer. Measure the input voltage using the power analyzer (item #3).

4.2.2. Adjust the electronic load (item #4) to the specified maximum output load current. Use a DVM (item #7) in series with the DC output or the electronic load

ammeter may also be used. If the power supply being tested has multiple DC voltage outputs adjust each DC output to the specified maximum output load current. Readjust the input AC voltage if it changed.

- 4.2.3. Using the power analyzer (item #3), measure and record the input AC current,  $I_{IN}$ , versus the input AC voltage,  $V_{IN}$ .
- 4.2.4. Holding the input AC voltage constant, adjust the electronic load(s) on the DC output(s) to the next load current(s) as desired. Readjust the input AC voltage (item #2) if it has changed. Repeat the measurements of 4.2.3 for each current.
- 4.2.5. Repeat 4.2.2 through 4.2.4 while adjusting the input AC voltage transformer in steps, as desired, from the maximum to the minimum rated input levels for the AC voltage.

### 4.3 EFFICIENCY

- 4.3.1. Set the input AC voltage to the maximum specified input level using the adjustable transformer. Measure the input voltage using the power analyzer (item #3).
- 4.3.2. Adjust the electronic load (item #4) to the specified maximum output load current. If the power supply being tested has multiple DC voltage outputs adjust each DC output to the specified maximum output load current. Readjust the input AC voltage if it changed.
- 4.3.3. Using the power analyzer (item #3), measure and record the input AC “real power,”  $P_{IN(real)}$ .
- 4.3.4. Calculate the power of the DC output(s) using the following equation:

$$P_{TOTAL} = \sum_{m=1}^n P_{OUT_m} = \sum_{m=1}^n (V_{OUT_m} \times I_{OUT_m}) \quad (7)$$

- 4.3.5. Calculate and record the efficiency using Equation 3.
- 4.3.6. Holding the input AC voltage constant, adjust the electronic load(s) on the DC output(s) to the next load current(s) as desired. Readjust the input AC voltage if it changed. Repeat the measurements of 4.3.3 through 4.3.5 for each current.
- 4.3.6. Repeat 4.3.2 through 4.3.6 while adjusting the input AC voltage transformer in steps, as desired, from the maximum to the minimum rated input levels for the AC voltage.

#### 4.4 LOAD REGULATION

- 4.4.1. Connect the DC voltmeter to the output of the power supply when making a DC voltage measurement.
- 4.4.2. Using the power analyzer (item #3), set the input AC voltage to the maximum specified input level using the adjustable transformer (item #2).
- 4.4.3. Adjust the electronic load (item #4) to the specified maximum output load current. If the power supply being tested has multiple DC voltage outputs adjust each DC output to the specified maximum output load current. Readjust the input AC voltage if it changed.
- 4.4.4. Using the DC voltmeter (item #7), measure and record the DC voltage,  $V_{OUT}$ .
- 4.4.5. Adjust the electronic load(s) on the DC output(s) to the next desired value of current load. Readjust the input AC voltage if it changed. Using the DC voltmeter (item #7), measure and record the DC voltage. Calculate and record the load regulation from Equation 5.
- 4.4.6 Repeat 4.4.5 for each desired load current using uniform steps, as desired, from the maximum to the minimum rated levels for each output current.

#### 4.5 LINE REGULATION

- 4.5.1. Connect the DC voltmeter to the output of the power supply when making a DC voltage measurement (item #7).
- 4.5.2. Using the power analyzer (item #3), set the input AC voltage to the maximum specified input level using the adjustable transformer (item #2).
- 4.5.3. Adjust the electronic load (item #4) to the specified maximum output load current. If the power supply being tested has multiple DC voltage outputs adjust each DC output to the specified maximum output load current. Readjust the input AC voltage if it changed.
- 4.5.4 Using the DC voltmeter (item #7), measure and record the DC voltage,  $V_{OUT}$ .
- 4.5.5. Adjust the AC input voltage using the adjustable transformer (item #2) to the next desired value. Using the DC voltmeter (item #7), measure and record the DC voltage for each input setting. Calculate and record the line regulation from Equation 4.

- 4.5.6. Repeat 4.5.5 for the entire AC input voltage range using uniform steps, as desired, from the maximum to the minimum rated levels for input AC voltage.

#### 4.6. NOISE AND RIPPLE

- 4.6.1. Connect an oscilloscope (item #5) to the output of the power supply with a 1:1 probe (item #6). The probe should consist of a short section of shielded coaxial cable.
- 4.6.2. For best results, minimize the distance from the power supply printed wiring board (PWB) to the probe on both the DC out and the ground connections. Shorter lead lengths lower the potential for picking up extraneous noise during the measurement.
- 4.6.3. If the final stages of power supply filtering are external to the DUT, it is permissible to include the filtering circuitry in this test. This should be done by placing the DUT and the filtering circuitry in their "intended device." The connections between the filtering circuitry and the "intended device" must be broken to allow connection of the DUT output to the electronic load. The scope probe should be connected as close as possible to the output of the filtering circuitry.
- 4.6.4. If possible, remove the alligator clip ground from the probe and take a very small jumper from the ground of the PWB to the ground sheath of the probe (refer to Figure 3).
- 4.6.5. Using the power analyzer (item #3), set the input AC voltage (item #2) to the maximum specified input level using the adjustable transformer.
- 4.6.6. Adjust the electronic load (item #4) to the specified maximum output load current. If the power supply being tested has multiple DC voltage outputs adjust each DC output to the specified maximum output load current. Readjust the input AC voltage if it changed.
- 4.6.7. Using the oscilloscope (item #5) with the 20 MHz bandwidth limit filter enabled, measure and record the peak-to-peak amplitude of the DC output voltage ripple and switching noise (Note that when using a digital sampling oscilloscope to measure noise and transient type signals, that some form of peak-detection sampling should be used).
- 4.6.8. The noise and ripple amplitude is the highest peak-to-peak combination of the

power line frequency (and harmonically related) ripple and the other high frequency noise. Record the noise and ripple amplitude.

- 4.6.9 Holding the input AC voltage constant, adjust the electronic load(s) on the DC output(s) to the next load current(s) as desired. Readjust the input AC voltage if it changed. Repeat the measurements of 4.6.7 through 4.6.8 for each current.
- 4.6.10 Repeat 4.6.6 through 4.6.9 while adjusting the input AC voltage transformer in steps, as desired, from the maximum to the minimum rated input levels for the AC voltage.

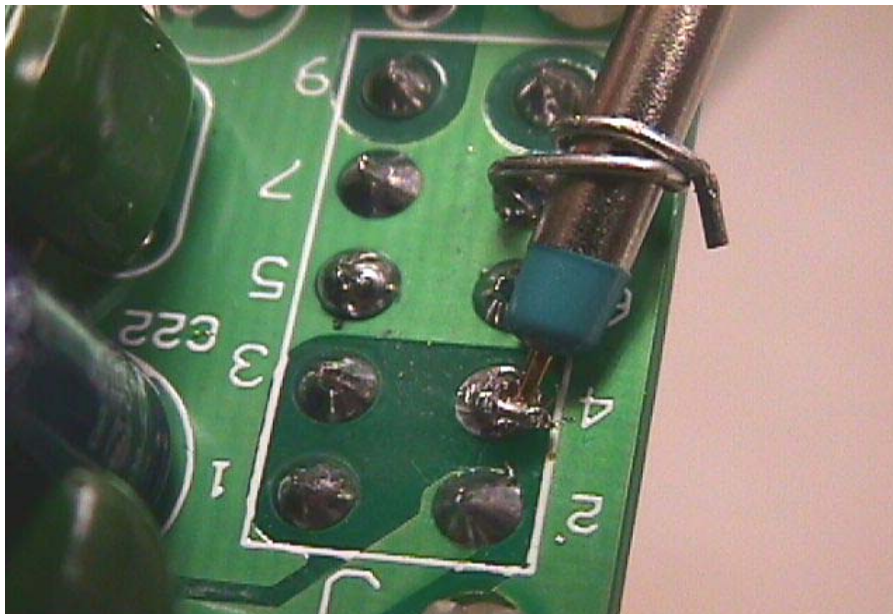

Figure 3: Probe connection example

## 4.7 HOLD-UP TIME

- 4.7.1. Using a dual channel digitizing storage oscilloscope (item #5), probe the DC output on channel 1 and the AC input on channel 2. If the DUT has more than one output, all outputs should be tested and characterized. Set up the oscilloscope as outlined below:

Table 2:

Vertical Scale	As appropriate
Horizontal Scale	As appropriate
Pre-trigger	ON
CH1 Vertical Coupling	DC
CH2 Vertical Coupling	AC
Trigger Mode	Normal or Single
Trigger Threshold	10% below DC out minimum spec.
Trigger Source	CH1 (DC output)
Trigger Slope	Negative
Trigger Coupling	DC

- 4.7.2 Verify that the DUT is operating and set the load at the output(s) using the electronic load(s) to the specified maximum output load current. Note that in this test, all output(s) must be properly loaded although only one output is measured at a time. Set the AC power source to the minimum specified operating voltage.
- 4.7.3 Find out where you are within the cycle, to make sure you have zero crossing correct to within  $\pm 1$  milliseconds. Turn the AC source off. The oscilloscope should have triggered as the output voltage decreased below the trigger threshold. The oscilloscope should display the AC and DC waveforms similar to the sample plot in Figure 4.
- 4.7.4 The holdup time is the time duration of when the AC input voltage is removed to the time until the output voltage falls below the minimum specification. The AC input voltage shall be removed within  $\pm 1$  milliseconds of the zero crossing. This is shown in Figure 4 by the two vertical cursors. Record the holdup time.
- 4.7.5 If the DUT has multiple DC voltage outputs, repeat 4.7.1 through 4.7.6 for each output.

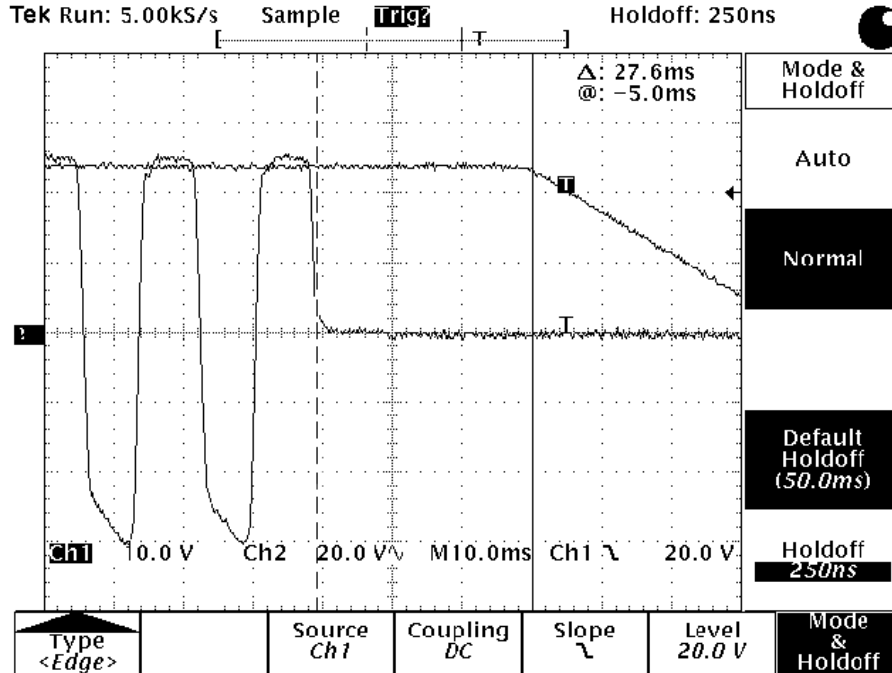

Figure 4: Holdup Time

## 4.8 INRUSH CURRENT

4.8.1 Feed the non-grounded DUT AC voltage input line through the wide-band current monitor (item #9). Connect the output of the current monitor to channel 1 of the digitizing oscilloscope (item #5).

4.8.2. Configure the oscilloscope as outlined in the table below:

Table 3.

Vertical Scale (CH1)	As appropriate
Horizontal Scale	As appropriate
Pre-trigger	ON
CH1 Vertical Coupling	DC
Trigger Mode	Single
Trigger Threshold	50% of AC current
Trigger Source	CH1 (AC current)
Trigger Slope	Positive
Trigger Coupling	DC

4.8.3. Set the input AC voltage to the maximum specified input level using the adjustable transformer (item #2).

- 4.8.4. Adjust the electronic load to the specified maximum output load current. If the power supply being tested has multiple DC voltage outputs adjust each DC output to the specified maximum output load current. Readjust the input AC voltage if it changed.
- 4.8.5. Turn off the AC input voltage to the DUT and allow all of the capacitors to fully discharge (>99% discharged). Consult the manufacturers data for the AC/DC power pack to determine the capacitor locations and normal voltages present within the power pack.
- 4.8.6. Verify that the DUT has zero DC output, then turn on the AC supply. It is required that the AC supply voltage is applied to within  $\pm 1$  milliseconds of the zero crossing point.
- 4.8.7. The oscilloscope should display a few impulses after the time the AC supply was turned on. These impulses are related to the inrush current.
- 4.8.8. The inrush current is the peak level of the highest of the inrush impulses multiplied by the current to voltage ratio as stated on the current monitor. This ratio is typically 0.1 volt per ampere. Refer above to Figure 5. Record the inrush current.

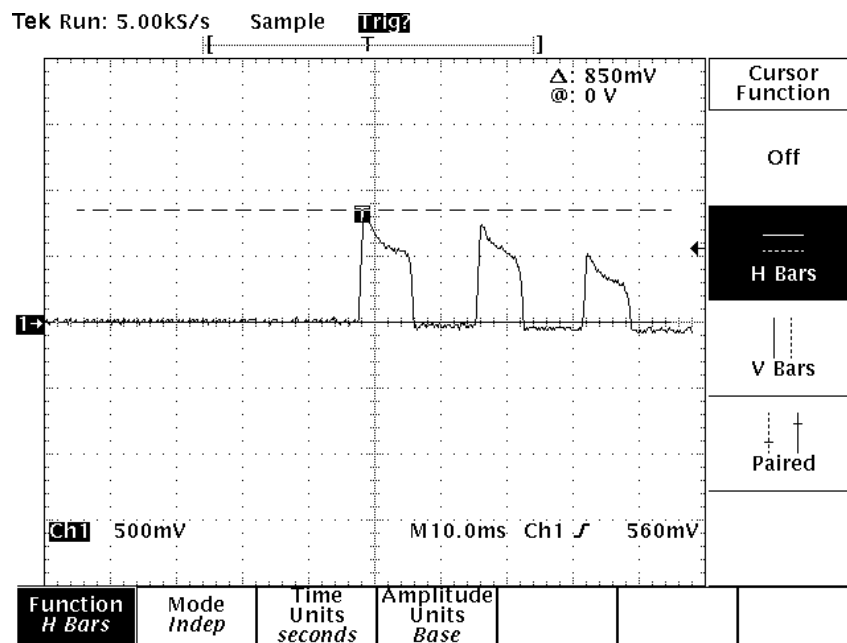

Figure 5: Inrush Current

- 4.8.9. Holding the input AC voltage constant, adjust the electronic load(s) on the DC output(s) to the next load current(s) as desired. Readjust the input AC voltage if it

changed. Repeat the measurements of 4.8.5 through 4.8.8 for each current.

4.8.10. Repeat 4.8.4 through 4.8.9 while adjusting the input AC voltage transformer in steps, as desired, from the maximum to the minimum rated input levels for the AC voltage.

#### 4.9. STARTUP TIME

4.9.1. Use the inrush current set up as specified in section 4.8. Channel 1 should be monitoring the AC input current. Connect Channel 2 to the DC output voltage.

4.9.2. Configure the oscilloscope as outlined in the Table 3:

Table 3.

Vertical Scale (CH1 & 2)	As appropriate
Horizontal Scale	As appropriate
Pre-trigger	ON (>75%)
CH1 Vertical Coupling	DC
CH2 Vertical Coupling	DC
Trigger Mode	Normal or Single
Trigger Threshold	DC out minimum spec.
Trigger Source	CH2 (DC output)
Trigger Slope	Positive
Trigger Coupling	DC
Record Length	At maximum

4.9.3. Set the input AC voltage to the maximum specified input level using the adjustable transformer.

4.9.4. Adjust the electronic load to the specified maximum output load current. If the power supply being tested has multiple DC voltage outputs adjust each DC output to the specified maximum output load current. Readjust the input AC voltage if it changed.

4.9.5. Turn the AC supply “off” and allow time for the filter capacitors to fully discharge (discharge > 99%).

4.9.6. Find out where you are within cycle, to make sure you have zero crossing correct to within  $\pm 1$  milliseconds. Turn the AC supply “on” and measure the time from the first inrush current impulse to the point where the DC output voltage reaches the minimum operating specification. Refer to Figure 6.

- 4.9.7. Holding the input AC voltage constant, adjust the electronic load(s) on the DC output(s) to the next load current(s) as desired. Readjust the input AC voltage if it changed. Repeat the measurements of 4.9.5 through 4.9.6 for each current.
- 4.9.8. Repeat 4.9.4 through 4.9.7 while adjusting the input AC voltage transformer (item #2) in steps, as desired, from the maximum to the minimum rated input levels for the AC voltage.

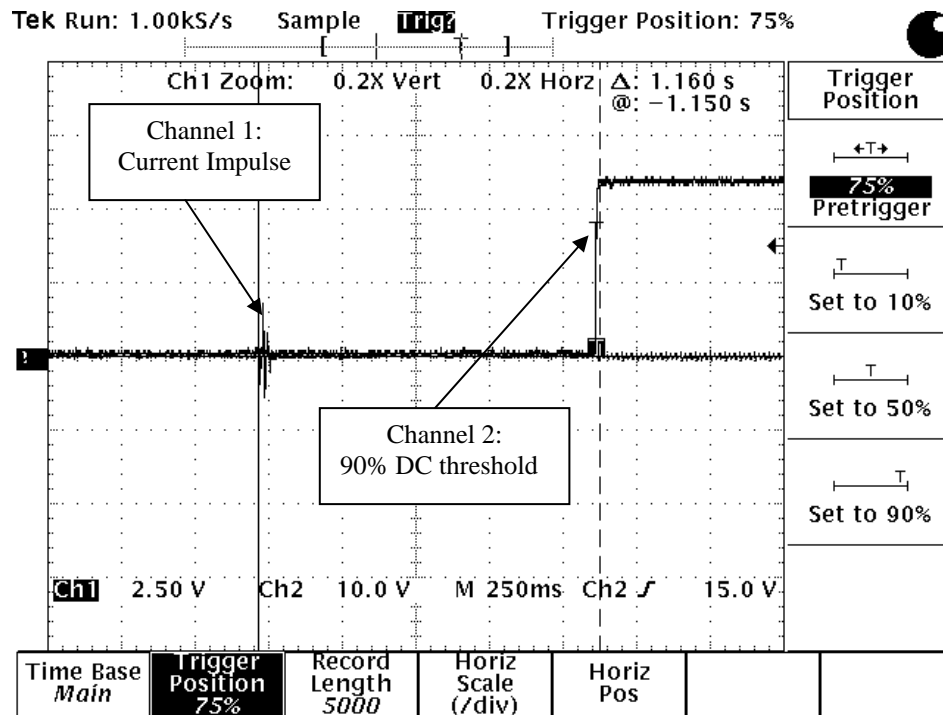

Figure 6 : Startup Time

#### 4.10. POWER FACTOR

- 4.10.1 Connect the DUT to the setup as shown in Figure 2. Insert the  $1\ \Omega$  power resistor (item #12) in Figure 2
- 4.10.2 Set the AC voltage to the maximum specified input level using the adjustable transformer (item #2).
- 4.10.3 Adjust the electronic load (item #4) to the specified maximum output load current. If the power supply being tested has multiple DC voltage outputs, adjust each output to the specified maximum output load current. Readjust the input AC voltage if it has changed.

- 4.10.4 Using the power analyzer (item #3) measure and record the power factor. If the power analyzer does not measure power factor, measure and record the AC input power,  $P_{IN(real)}$ , AC input voltage,  $V_{IN}$ , and AC input current,  $I_{IN}$ , and calculate the power factor from Equations 1 and 6.
- 4.10.5 Holding the input AC voltage constant, adjust the electronic load(s) on the DC output(s) to the next load current(s) as desired. Readjust the input AC voltage if it changed. Repeat the measurement of 4.10.4 for each current.
- 4.10.6 Repeat 4.10.3 through 4.10.5 while adjusting the input AC voltage transformer in steps, as desired, from the maximum to the minimum rated input levels for the AC voltage.

NOTE: The following set of tests are considered optional. They are unnecessary for power factor corrected supplies.

- 4.10.7 The previous series of tests were performed using the 1  $\Omega$  series resistor. The following steps will increase the resistance to simulate the coaxial loop resistance. Insert the 5  $\Omega$  power resistor (item #13) in Figure 2
- 4.10.8 Set the AC voltage to the maximum specified input level using the adjustable transformer (item #2).
- 4.10.9 Adjust the electronic load (item #4) to the specified maximum output load current. If the power supply being tested has multiple DC voltage outputs, adjust each output to the specified maximum output load current. Readjust the input AC voltage if it has changed.
- 4.10.10 Using the power analyzer (item #3) measure and record the power factor. If the power analyzer does not measure power factor, measure and record the AC input power,  $P_{IN(real)}$ , AC input voltage,  $V_{IN}$ , and AC input current,  $I_{IN}$ , and calculate the power factor from Equations 1 and 6.
- 4.10.11 Holding the input AC voltage constant, adjust the electronic load(s) on the DC output(s) to the next load current(s) as desired. Readjust the input AC voltage if it changed. Repeat the measurement of 4.10.10 for each current.

## 5.0 NORMATIVE REFERENCES

ANSI/SCTE 96 2003  
ANSI/SCTE 82 2003