

Scanned Datasheet

Notice: You cannot copy or search the text in this PDF file, because this PDF file is converted from a scanned image of printed materials.

Resources

[Datasheet Archive - Datasheet & Application Note Search Engine](#)

[SupplyFrame - Datasheet & Application Note Search Engine](#)

YM3812

FM OPERATOR TYPE-L II (OPL II)

■ OVERVIEW

The FM Operator Type-LII (OPLII) is a new type of sound generator designed for use with Captain systems and videotext systems. This allows for the production of a wide variety of sounds using software control. This sound generator is also equipped with functions for the production of rhythm sounds.

The OPLII also has a built-in low frequency oscillator for vibrato and AM effects, reducing the amount of programming required to produce special effects.

As this sound output from OPLII is digital, a D/A converter such as YM3014 is necessary.

■ FEATURES

- FM sound generation system for realistic sound
- Mode selection of simultaneous voicing of 9 sounds or 6 melody sounds and 5 rhythm sounds is possible. Both modes can produce various sounds.
- Built-in vibrato oscillator/amplitude modulation oscillator (AM)
- Composite sine wave speech synthesis also possible
- Input/output TTL compatible
- Si-gate CMOS-LSI
- 5V single power supply

■ PIN LAYOUT

VSS	1	24	ϕM
\overline{IRQ}	2	23	ϕSY
\overline{IC}	3	22	NC
AO	4	21	MO
\overline{WR}	5	20	SH
\overline{RD}	6	19	NC
\overline{CS}	7	18	D7
NC	8	17	D6
NC	9	16	D5
DO	10	15	D4
DI	11	14	D3
GND	12	13	D2

* NC : No Connection

■ BLOCK DIAGRAM

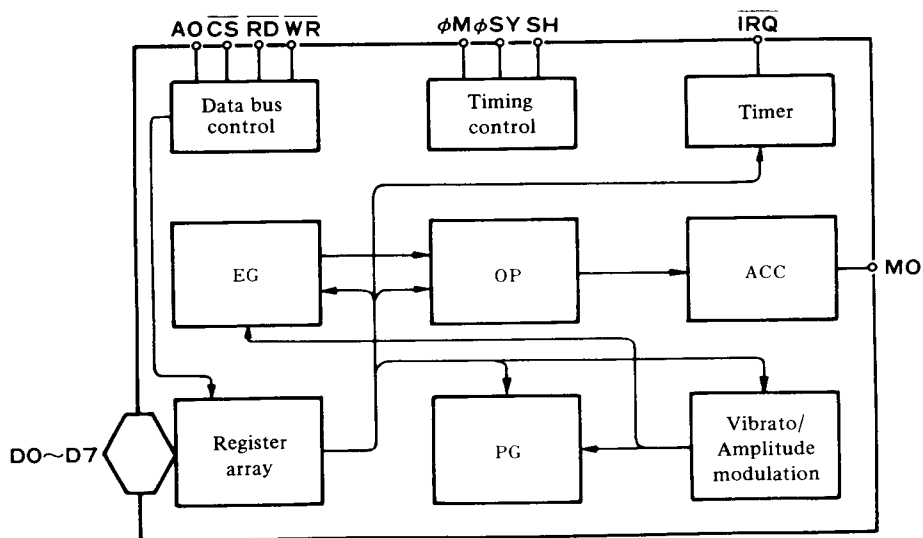

■ DESCRIPTION OF PIN FUNCTIONS

- a) ϕM
Master clock of OPL; input frequency is 3.58MHz.
- b) $\phi SY \cdot SH$
Clock (ϕSY) and Synchronization Signal (SH) to convert digital output of FM sound generator to analog signal.
- c) $D0 \sim D7$
8 bit bidirectional data communication between OPLII and processor.
- d) $\overline{CS} \cdot \overline{RD} \cdot \overline{WR} \cdot A0$
Control data bus comprised of $D0 \sim D7$.

\overline{CS}	\overline{RD}	\overline{WR}	A0	
0	1	0	0	Write address of register to OPL
0	1	0	1	Write contents of register to OPL
0	0	1	0	Status of OPL is read.
0	0	1	1	Data of data bus not assured
1	×	×	×	Set data bus $D0 \sim D7$ to high impedance

- e) \overline{IRQ}
Interrupt signal sent from either of two timers. Interrupts can be masked by program.
- f) \overline{IC}
Set the contents of registers to "0" and the system will be reset when driven to low level.
- g) MO
Digital output of FM sound generator. The external D/A convertor unit is necessary.
- h) V_{cc}
+ 5V power supply pin
- i) GND
Ground pin

■ DESCRIPTION OF FUNCTIONS

OPLII has two sounding modes: nine melodies, and a combination of six melodies and five rhythms. This mode selection can be controlled by the program. For melodies, the same FM sound generator as used in the Yamaha DX-7 synthesizer is used for creating excellent sound quality.

For this reason, this LSI is the most suitable for sound generators for new media-related equipment, including CAPTAIN systems and teletex.

Frequency modulation for this LSI is obtained by the following expressions. Either sine waves synthesis (1) or frequency modulation (2) can be programmed for individual sounds.

$$F_1 = I_1 \sin w_1 t + I_2 \sin w_2 t \quad -(1)$$

$$F_2 = I_2 (w_1 t + I_2 \sin w_2 t) \quad -(2)$$

A noise generator and synthesizer are provided for rhythmic sounds. Sounding requires no special external control. Five rhythmic sounds: bass drum (BD), snare drum (SD), high-hat cymbals (HH), top cymbal (TC) and tom-tom (TOM) can be generated.

The internal parts of OPL are functionally divided into nine blocks to perform the following:

- (a) Register array:
OPL is controlled by the register array contents and the shape of the envelope and phase data are determined.
- (b) Phase generator (PG):
A phase of the FM sound generator at each time step is generated. This receives and accumulates phases from the register array, thereby calculating a phase at each time step.
- (c) Envelope generator (EG):
This generates an envelope and modulation index for each sound. This generator receives instructions for such items as slope (rate) and offset (total level) from the register array to generate an envelope.
- (d) Operator (OP):
The operator receives phase information (θ) from PG and envelope information (E) from EG, and calculates $E\sin\theta$.
- (e) Accumulator (ACC):
The accumulator is used to accumulate each sound at each sampling time (50 KHz) in order to convert data to match the D/A converter.
- (f) Vibrato oscillator/amplitude modulation oscillator:
Low frequency oscillators for vibrato and amplitude modulation. The oscillation frequency is 6.4 Hz for vibrato and 3.7 Hz for amplitude modulation.
- (g) Timers:
There are two types for general-purpose timers for long and short.
- (h) Data bus control.
- (i) Timing control.

■ CONTENTS OF EACH REGISTER

	Address	
1	01	TEST information. Usually set to "0". On this stage the waveform is Sine wave and compatible with YM3526. If any waveform other than Sine wave will be selected, set D5 to "1".
2	02	Times setting on timer 1. 80μs~20.4ms
3	03	Times setting on timer 2. 320μs~82ms
4	04	Controls the operation of timers 1 and 2 and resets interrupt signals.
5	08	CSM is for the CSM speech synthesis modie. NOTE SEL is for switching the keyboard split by using the F-Number.
6	20~35	MULTI controls the relationship between fundamental waves and harmonics. KSR is key scale of RATE. EG-TYPE is for the switching of Non Percussive Tone and Percussive Tone. 0 is for Percussive Tone and 1 is for Non Percussive Tone. VIB indicates the ON/OFF of vibrato. AM indicates the ON/OFF of modulation.
7	40~55	TL provides a total level for adjustment of each sound level. KSL is the level key scale.
8	60~75	DR sets the decay rate at the decay time. AR sets the rate of increase at the attack time.
9	80~95	RR provides the decay rate at Release/Sustain time. SL provides the level for shifting from decay to sustain.
10	A0~B8	F-Number provides chords within one octave, Block represents octave information for each sound. KON indicates that the sound being generated when it is "1".
11	BD	Controls rhythmic sounds and the corresponding bits for setting ON/OFF of each rhythm. When the R bit is 1, the system is in the rhythm mode. VIB DEP indicates the depth of vibrato. 0 = 7ø, 1 = 14ø. AM DEP indicates the depth of amplitude modulation. 0 = 1dB, 1 = 4.8dB.
12	C0~C8	FB indicates FM feedback factor. C indicates Sin wave synthesis or FM modulation.
13	E0~F5	Wave Select signal. When D5 of address \$01 is "1", four kinds of waveform can be selected.

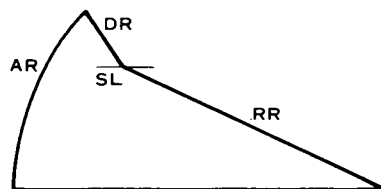

Percussive Tone

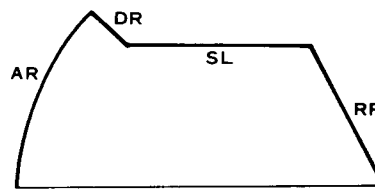

Non Percussive Tone

■ ELECTRICAL CHARACTERISTICS

1. Absolute Maximum Ratings

	Rating	Units
Pin voltage	-0.3 ~ 7.0	V
Operating ambient temperature	0 ~ 70	°C
Storage temperature	-50 ~ 125	°C

2. Recommended Operating Conditions

Item	Symbol	Minimum	Typical	Maximum	Unit
Power voltage	Vcc	4.5	5	5.5	V
	GND	0	0	0	V

3. DC Characteristics

Item	Symbol	Conditions	Minimum	Typical	Maximum	Unit
Input high level voltage	All input VIH		2.0			V
Input low level voltage	All input VIL				0.8	V
Input leak current	$\emptyset M \cdot \overline{WR} \cdot \overline{RD} \cdot A_0$ IL	Vin = 0 ~ 5V	-10		10	μA
Three-state (OFF state) input current	D0 ~ D7 ITSL	Vin = 0 ~ 5V	-10		10	μA
Output high level voltage	Output expect \overline{IRQ} VOH1	IOH1 = 0.4mA	2.4			V
		IOH2 = 40μA	3.3			V
Output low level voltage	All output VOL	IOL = 2.0mA			0.4	V
Output leak current (OFF state)	\overline{IRQ} ILOFF	VOH = 0 ~ 5V	-10		10	V
Pullup resistance	$\overline{IC}, \overline{CS}$ RPU		80		400	KΩ
Input capacity	All input CI				10	PF
Output capacity	All output CO				10	PF
Power voltage	ICC				30	mA

4. AC Characteristics

Item	Symbol	Conditions	Minimum	Typical	Maximum	Unit
Input clock frequency	$\emptyset M$ fC	Fig. A-1	2.0	3.58	4.0	MHz
Input clock duty cycle	$\emptyset M$		40	50	60	%
Input clock rise time	$\emptyset M$ TR	Fig. A-1				ns
Input clock fall time	$\emptyset M$ Tr	Fig. A-1				ns
Address setup time	A0 TAS	Fig. A-2, Fig. A-3	10			ns
Address hold time	A0 TAH	Fig. A-2, Fig. A-3	20			ns
Chip select write width	\overline{CS} TCSW	Fig. A-2	100			ns
Chip select read width	\overline{CS} TCSR	Fig. A-3	200			ns
Write pulse write width	\overline{WR} TWW	Fig. A-2	100			ns
Write data setup time	D0 ~ D7 TDS	Fig. A-2	20			ns
Write data hold time	D0 ~ D7 TDH	Fig. A-2	30			ns
Read pulse width	\overline{RD} TRW	Fig. A-3	200			ns
Read data access time	D0 ~ D7 TACC	Fig. A-3			200	ns
Read data hold time	D0 ~ D7 TRDH	Fig. A-3	10			ns
Output rise time	$\emptyset SY$ TOR1	Fig. A-4			100	ns
	MO-SH TOR2	Fig. A-5			150	ns
Output fall time	$\emptyset SY$ TOF1	Fig. A-4			100	ns
	MO-SH TOF2	Fig. A-5			150	ns
Reset pulse width	\overline{IC} NICW	Fig. A-6	80			Cycle

■ REGISTER MAP

ADDRESS	D7	D6	D5	D4	D3	D2	D1	D0	COMMENT	
01				TEST					TEST DATA OF LSI D5 indicates WAVE SELECT ENABLE.	
02				TIMER-1					DATA OF TIMER-1	
03				TIMER-2					DATA OF TIMER-2	
04	RST	MASK T1 T2		/			ST2ST1		IRQ-RESET/CONTROL OF RIMER-1, 2	
08	CSMSEL		/					CSM SPEECH SYNTHESIS MODE/NOTE SELECT		
20	AM	VIB						EG-TYP	KSR	MULTI
35										
40	KSL		TL						KSL/TOTAL LEVEL	
55										
60	AR			DR						ATTACK RATE/DECAY RATE
75										
80	SL			RR						SUSTAIN RATE/RELEASE RATE
95										
A0	F-Number (L)								KON/BLOCK/F-Number	
A8										
B0	/		KON	BLOCK			F-Num (H)			
B8										
BD	DEP AM VIB		R	BD	SD	TOM	TC	HH	DEPTH(AM/VIB)/RHYTHM(BD·SD·TOM·TC·HH)	
C0	/			FB		C			FEEDBACK/CONNECTION	
C8										
E0	/			WS						WAVE SELECT
F5										

■ STATUS REGISTERS

IRQ	FLAG T1 T2	/			IRQ/FLAG(T1, T2)
-----	---------------	---	--	--	------------------

■ TIMING DIAGRAMS (Timing is based upon settings of $V_{IH} = 2.0V$ and $V_{IL} = 0.8V$)

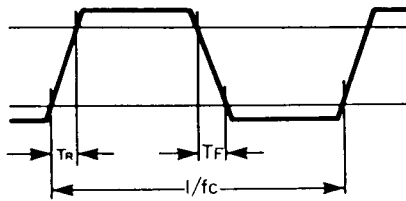
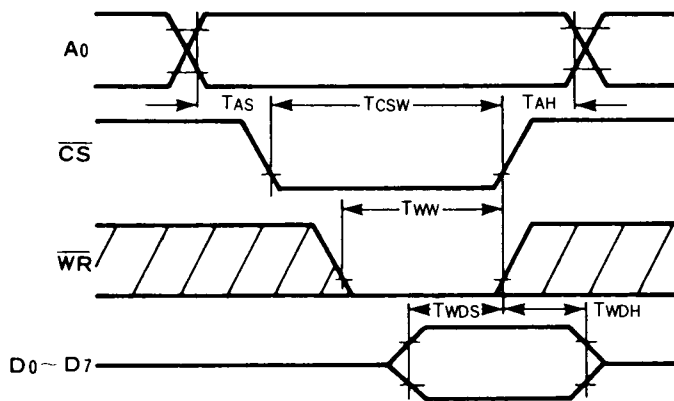
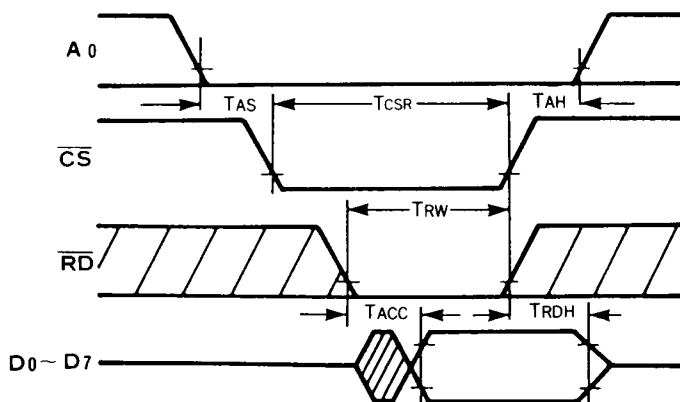

Fig. A-1 Clock Timing



Note: T_{CSW} , T_{WW} , and T_{WDH} are based on either \overline{CS} or \overline{WS} being driven to high level.

Fig. A-2 Write Timing



Note: T_{ACC} is based on whichever of \overline{CS} or \overline{RD} goes to the low level last. T_{CSR} , T_{RW} , and T_{RDH} are based on either \overline{CS} or \overline{RD} being driven to high level.

Fig. A-3 Read Timing

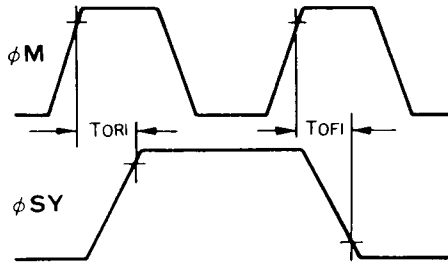

Fig. A-4 ϕM and ϕSY

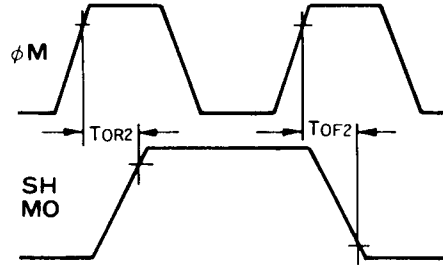

Fig. A-5 ϕM and SH·MO

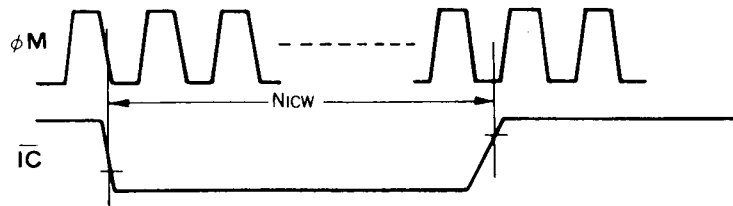

Fig. A-6 Reset Pulse

■ WAVE SELECT

When bit D₅ of address \$φ1 is “0”, the OPLII is fully compatible with YM3526 (OPL); there are no differences between the two devices. If a sine wave is input in this mode, the output will be a sine wave like the input. When bit D₅ of address \$φ1 is “1”, the input sine wave will be output as the distorted wave shown in Table 3-10.

SE0~SF5

D7	D6	D5	D4	D3	D2	D1	D0
/						WAVE SELECT	

Table 3-10 Wave Select

D1	D0	Waveform
0	0	
0	1	
1	0	
1	1	

■ DIMENSIONS

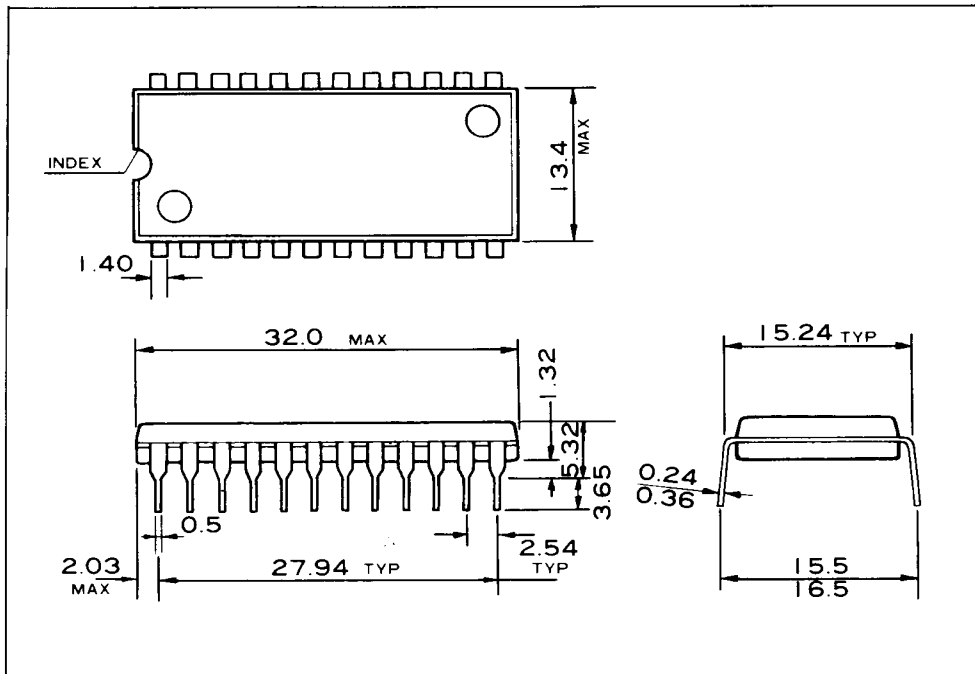

The specifications of this product are subject to improvement changes without prior notice.

_____ AGENCY _____

— NIPPON GAKKI CO., LTD —

■ **Head Office** 10-1, Nakazawa-cho, Hamamatsu-shi,
Shizuoka-ken, 430
Tel. 0534-65-1111

Address inquiries to:

Electronic System Division

■ **Toyooka Factory** 203, Matsunokijima, Toyooka-mura,
Iwata-gun, Shizuoka-ken, 438-01
Electronic Equipment business section
Tel. 053962-3125

■ **Tokyo Office** 3-4, Surugadai Kanda, Chiyoda-ku,
Tokyo, 104
Ryumeikan Bldg. 4F
Tel. 03-255-4481

■ **Osaka Office** 1-16, Shin-ashiyashimo, Suita-shi,
Osaka, 565
Tel. 06-877-7731

007695 ✓ X